



Version	2.1
Total pages	17
Date	2004.11.09

## Product Specification

7" color TFT-LCD module

MODEL NAME: A070VW01

- ( ◆ ) Preliminary Specification
- ( ..... ) Final Specification

Note: The content of this specification is subject to change.

© 2004 AU Optronics  
All Rights Reserved,  
Do Not Copy.





**Contents:**

**A. Physical specification..... P3**

**B. Electrical specifications..... P4**

    1. Pin assignment..... P4

        a. TFT-LCD panel driving section..... P4

        b. Backlight driving section..... P5

    2. Absolute maximum ratings..... P5

    3. Electrical characteristics..... P6

        a. Typical operating conditions..... P6

        b. Current consumption..... P6

        c. Backlight driving conditions..... P6

    4. AC Timing..... P7

        a. Timing conditions..... P7

        b. Timing diagram..... P7

**C. Optical specifications..... P8**

**D. Reliability test items..... P10**

**E. Packing form..... P11**



**Appendix:**

Fig.1 Outline dimension of TFT-LCD module (Front Side) . . . . .	<b>P12</b>
Fig.2 Operation Mode 1 . . . . .	<b>P13</b>
Fig.3 Operation Mode 2 . . . . .	<b>P14</b>
Fig.4 Horizontal timing . . . . .	<b>P15</b>
Fig5 Vertical shift timing	<b>P16</b>
Fig6 Vertical timing (from up to down)	<b>P17</b>

For AUO Sales Internal Use Only

**A. Physical specifications**

NO.	Item	Specification	Remark
1	Display resolution(dot)	800RGB(W)×480(H)	
2	Active area(mm)	152.40W)×91.44(H)	
3	Screen size(inch)	7.0(Diagonal)	
4	Pixel pitch(mm)	0.1905(W)×0.1905(H)	
5	Color configuration	R. G. B. stripe	
6	Overall dimension(mm)	165(W)×104(H)×6(D)	Note 1
7	Weight(g)	170 ±10	
8	Surface treatment	AG(5.5%) with WV film	
9	Backlight unit	CCFL	

Note 1: Refer to Fig. 1

## B. Electrical specifications

### 1. Absolute Maximum Ratings

Items	Symbol	Product Specification			Unit
		Min.	Typ.	Max.	
Power Voltage	V <sub>cc</sub>	-0.5		5	V
	AVDD	-0.5		12	V
	VGH	-0.3		18	V
	VGL	-15		0.3	V
	VGH-VGL			33	V
Input Signal Voltage	V <sub>i</sub>	-0.3		V <sub>cc</sub> +0.3	V
	V <sub>ref</sub> (V1~V5)	0.4AVDD		AVDD+0.3	V
	V <sub>ref</sub> (V6~V10)	-0.3		0.6AVDD	V
	V <sub>com</sub>		2.6		V
Operating Temperature	Topa	-30		85	°C
Storage Temperature	Tstg	-40		85	°C
CCFL	V <sub>L</sub>			3,000	V
	I <sub>L</sub>			10	mA

### 2. Typical operating conditions (GND=AVSS=0V)

Items	Symbol	Product Specification			Unit
		Min.	Typ.	Max.	
Power Voltage	V <sub>cc</sub>	3.0	3.3	3.6	V
	AVDD	8.6	8.8	9.0	V
	VGH	14.0	15.0	16.0	V
	VCOM		2.6		V
	VGL	-11.0	-10	-9.0	V
Input Reference Voltage	V1~V5	0.4AVDD	—	AVDD-0.2	V
	V6~V10	0.2	—	0.6AVDD	V
Input H/L level Voltage	V <sub>IH</sub>	0.8VCC	—	VCC	V
	V <sub>IL</sub>	0	—	0.2VCC	V

### 3. Current consumption conditions(GND=Avss=0V)

Parameter	Symbol	Condition	Min.	Typ.	Max.	Unit
Current For Driver	IGH	VGH=15V		100	150	uA
	IGL	VGL=-10V		-100	-150	uA
	ICC	VCC=5V		3.5	5	mA
	IDD	AVDD=5V		20	30	mA



4. Backlight driving conditions

Parameter	Symbol	Condition	Min.	Typ.	Max.	Unit
Voltage	VL		513	570	627	Vrms
Current	IL			6	7	mA
Frequency	FL			60	80	KHz
Lamp Start Voltage	Vs	T=25°C		890	1,110	Vrms
		T=0°C		1,160	1,460	Vrms
		T=-30°C		1,490	1,870	Vrms

5. Timing conditions

AC Electrical Characteristics (VCC=3.3V, AVDD=8.4V, AVSS=GND=0V, TA=25°C)

Parameter	Symbol	Min.	Typ.	Max.	Unit
CLK frequency	Fclk		40	42	MHz
CLK pulse width	TCW	6			ns
Data set-up time	Tsu	4			ns
Data hold time	Thd	2			ns
Propagation delay of DIO2/1	Tphl	6	10	15	ns
Time that the last data to LD	Tld	1			Tcw
Pulse width of LD	Twid	2			Tcw
Time that LD to DIO1/2	Tlds	5			Tcw
POL set-up time	Tpsu	6			ns
POL hold time	Tphd	6			ns
OEV pulse width	TOEV		12		Tcw
CKV pulse width	TCKV	16	28	40	Tcw
Horizontal display start	TSH		0		Tcw/3
Horizontal display timing range	TDH		800		Tcw/3
STV setup time	TSUV	400			ns
STV hold time	THDV	400			ns
STV pulse width	TSTV			1	TDH
Horizontal lines per field	TV	512	525	610	TDH
Vertical display start	TSV		3		TDH
Vertical display timing range	TDV		480		TDH

DC Electrical Characteristics

Parameter	Symbol	Min.	Typ.	Max.	Unit
Supply Voltage	Vcc	2.7	3.3	3.6	V
Low Level Input Voltage	Vil	0	-	0.3*Vcc	V
High Level Input Voltage	Vih	0.7*Vcc	-	Vcc	V
High Level Output Voltage	Voh	Vcc-0.4	-	-	V
Low Level Output Voltage	Vol	GND	-	GND+0.4	V
Supply Voltage	AVDD	6.5	8.8	10	V
Sinking Current of Outputs	IOL	-80	-	-	uA
Driving Current of Outputs	IOH	80	-	-	uA



1.Pin assignment

a. TFT-LCD panel driving section

(1.) FH12-50S-0.5SH(Hirose) — FPC I/O Pin Assignment

Pin no	Symbol	I/O	Description	Remark
1	GND	P	Ground for gate drive	
2	VCC	P	Digital voltage for gate driver	
3	VGL	P	TFT low voltage	
4	VGH	P	TFT high voltage	
5	STVL	I/O	Start pulse signal input/output (Vertical)	
6	STVR	I/o	Start pulse signal input/output (Vertical)	
7	CKV	I	CLK (Vertical)	
8	U/D	I	Up or Down display control	
9	OEV	I	Output enable	
10	VCOM	I	VCOM voltage	
11	DIO1	I/O	Start pulse signal input/output (Horizontal)	
12	AVDD	P	Analog voltage for source driver	
13	AVSS	P	Analog ground for source driver	
14	GND	P	Digital ground for source driver	
15	VCC (DVDD)	P	Digital voltage for source driver	
16	EDGSL	I	Select raising edge or raising/falling edge	
17	CLK	I	Sample CLK	
18	SHL(R/L)	I	Right or Left display control	
19	R0	I	Red data	
20	R1	I	Red data	
21	R2	I	Red data	
22	R3	I	Red data	
23	R4	I	Red data	
24	R5	I	Red data	
25	G0	I	Green Data	
26	G1	I	Green Data	
27	G2	I	Green Data	
28	G3	I	Green Data	
29	G4	I	Green Data	
30	G5	I	Green Data	
31	V1	I	Reference voltage	
32	V2	I	Reference voltage	
33	V3	I	Reference voltage	
34	V4	I	Reference voltage	
35	V5	I	Reference voltage	
36	V6	I	Reference voltage	
37	V7	I	Reference voltage	
38	V8	I	Reference voltage	
39	V9	I	Reference voltage	
40	V10	I	Reference voltage	
41	B0	I	Blue Data	



42	B1	I	Blue Data	
43	B2	I	Blue Data	
44	B3	I	Blue Data	
45	B4	I	Blue Data	
46	B5	I	Blue Data	
47	LD (OEH)	I	Latch and switch data to output	
48	REV	I	Control data are inverted or not	
49	POL	I	Polarity selection	
50	DIO2	I/O	Start pulse signal input/output (Horizontal)	

For AUO Sales Internal Use Only

### C. Optical specification (Note 1, Note 2)

Item		Symbol	Condition	Min.	Typ.	Max.	Unit	Remark
Response time	Rise	Tr	$\theta = 0^\circ$	-	12	50	ms	Note 3,5
	Fall	Tf		-	18	60	ms	
Contrast ratio		CR	At optimized Viewing angle	200	300	-		Note 4, 5
Viewing angle	Top		$CR \geq 10$	30	40	-	deg.	Note 5, 6
	Bottom			50	60	-		
	Left			50	60	-		
	Right			50	60	-		
Viewing angle	Top		$CR \geq 5$	40	50	-	deg.	Note 5, 6
	Bottom			60	70	-		
	Left			60	70	-		
	Right			60	70	-		
Brightness		$Y_L$	$I_L = 6\text{mA}, 25^\circ\text{C}$	350	400	-	nit	Note 7
White chromaticity		X	$\theta = 0^\circ$	0.26	0.31	0.36		Note 7
		Y	$\theta = 0^\circ$	0.28	0.33	0.38		

Note 1 : Ambient temperature = 25°C, and lamp current  $I_L = 6 \text{ mA}$ . To be measured in the dark room.

Note 2 : To be measured on the center area of panel with a viewing cone of 1° by Topcon luminance meter BM-7, after 10 minutes operation.

Note 3. Definition of response time:

The output signals of photo detector are measured when the input signals are changed from "black" to "white" (falling time) and from "white" to "black" (rising time), respectively. The response time is defined as the time interval between the 10% and 90% of amplitudes. Refer to figure as below.

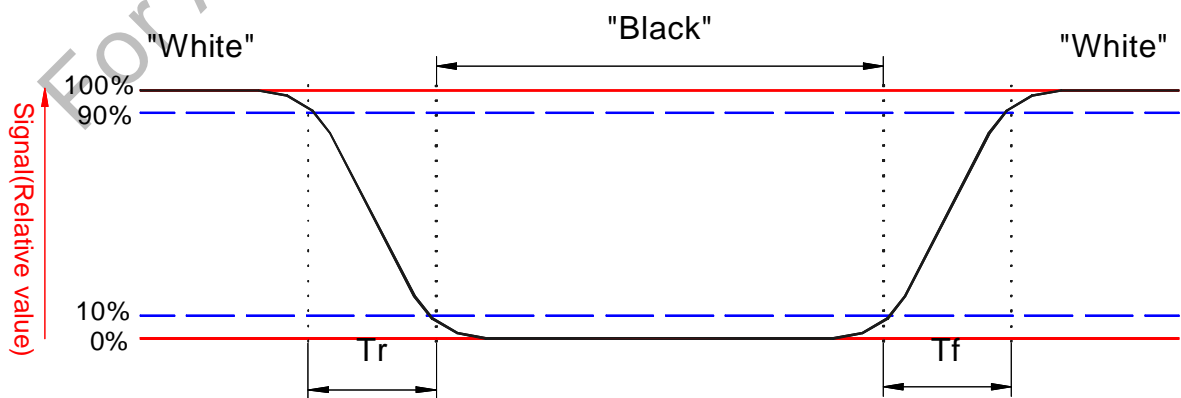

Note 4. Definition of contrast ratio:

Contrast ratio is calculated with the following formula.

$$\text{Contrast ratio (CR)} = \frac{\text{Photo detector output when LCD is at "White" state}}{\text{Photo detector output when LCD is at "Black" state}}$$

Note 5. White  $V_i = V_{i50} + 1.5V$

Black  $V_i = V_{i50} \pm 2.0V$

" $\pm$ " means that the analog input signal swings in phase with  $V_{COM}$  signal.

" $\mp$ " means that the analog input signal swings out of phase with  $V_{COM}$  signal.

$V_{i50}$  : The analog input voltage when transmission is 50%

The 100% transmission is defined as the transmission of LCD panel when all the input terminals of module are electrically opened.

Note 6. Definition of viewing angle, Refer to figure as below.

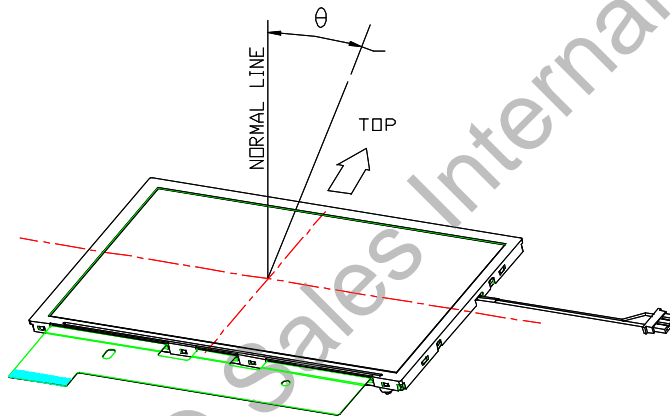

Note 7. Measured at the center area of the panel when all the input terminals of LCD panel are electrically opened.

**D. Reliability test items(Note 2):**

No.	Test items	Conditions	Remark
1	High temperature storage	Ta= 85°C                      240Hrs	
2	Low temperature storage	Ta= -40°C                      240Hrs	
3	High temperature operation	Tp= 85°C                      240Hrs	
4	Low temperature operation	Ta= -30°C                      240Hrs	
5	High temperature and high humidity	Tp= 60°C, 90% RH              240Hrs	Operation
6	Heat shock	-30°C~85°C/200 cycles 1Hrs/cycle	Non-operation
7	Electrostatic discharge	±200V,200pF(0Ω), once for each terminal	Non-operation
8	Vibration	Frequency range : 8~33.3Hz Stoke : 1.3mm Sweep : 2.9G, 33.3 ~ 400Hz Cycle : 15 minutes 2 hours for each direction of X,Z 4 hours for Y direction	JIS C7021, A-10 condition A
9	Mechanical shock	100G, 6ms, ±X,±Y,±Z 3 times for each direction	JIS C7021, A-7 condition C
10	Vibration (with carton)	Random vibration: 0.015G <sup>2</sup> /Hz from 5~200Hz -6dB/octave from 200~500Hz	IEC 68-34
11	Drop (with carton)	Height: 60cm 1 corner, 3 edges, 6 surfaces	JIS Z0202

Note1: Ta: Ambient Temperature.

Note2: Tp: Panel Surface Temperature

Note3: In the standard conditions, there is not display function NG issue occurred. All the cosmetic specification is judged before the reliability stress.

### E. Packing form

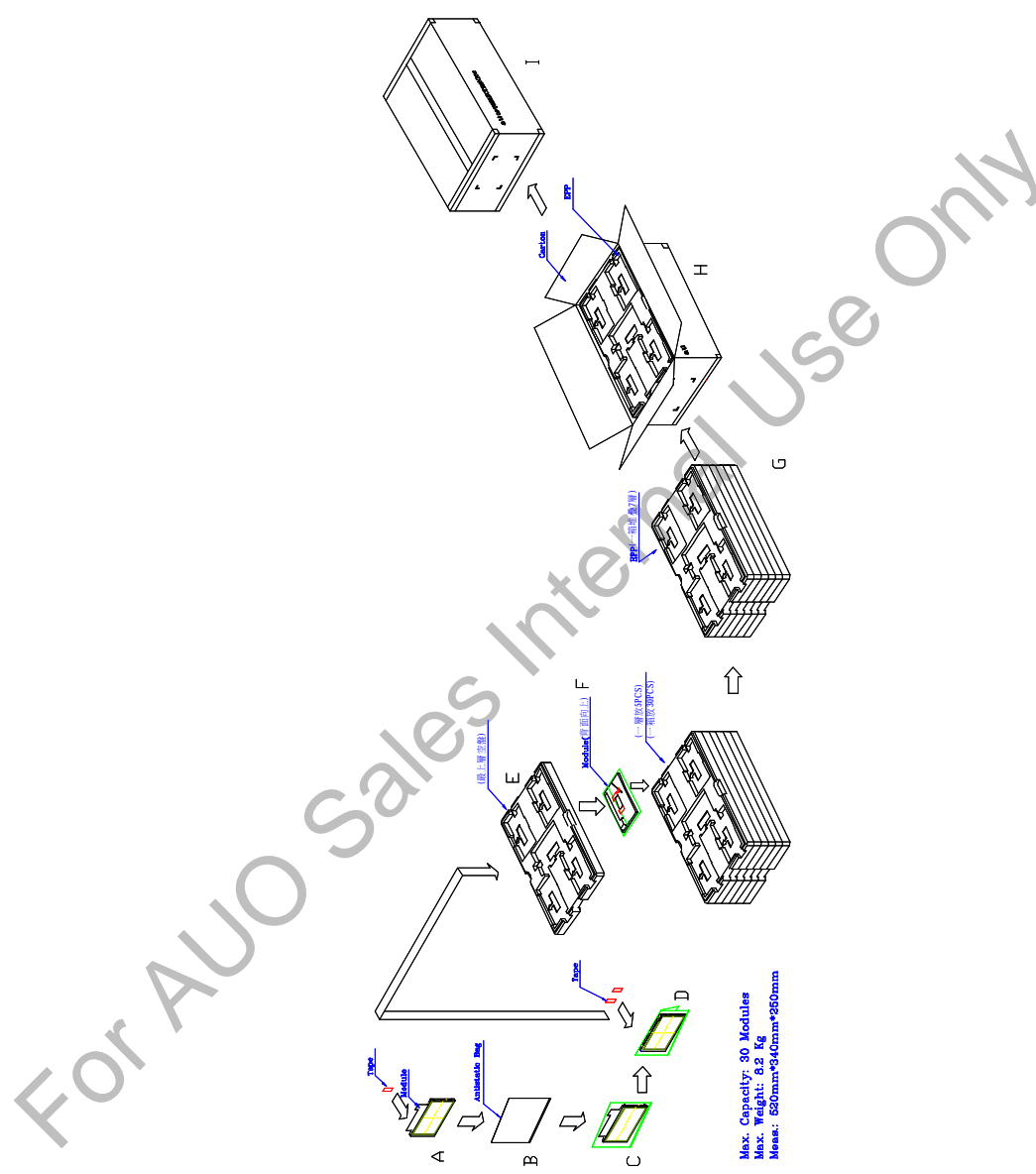

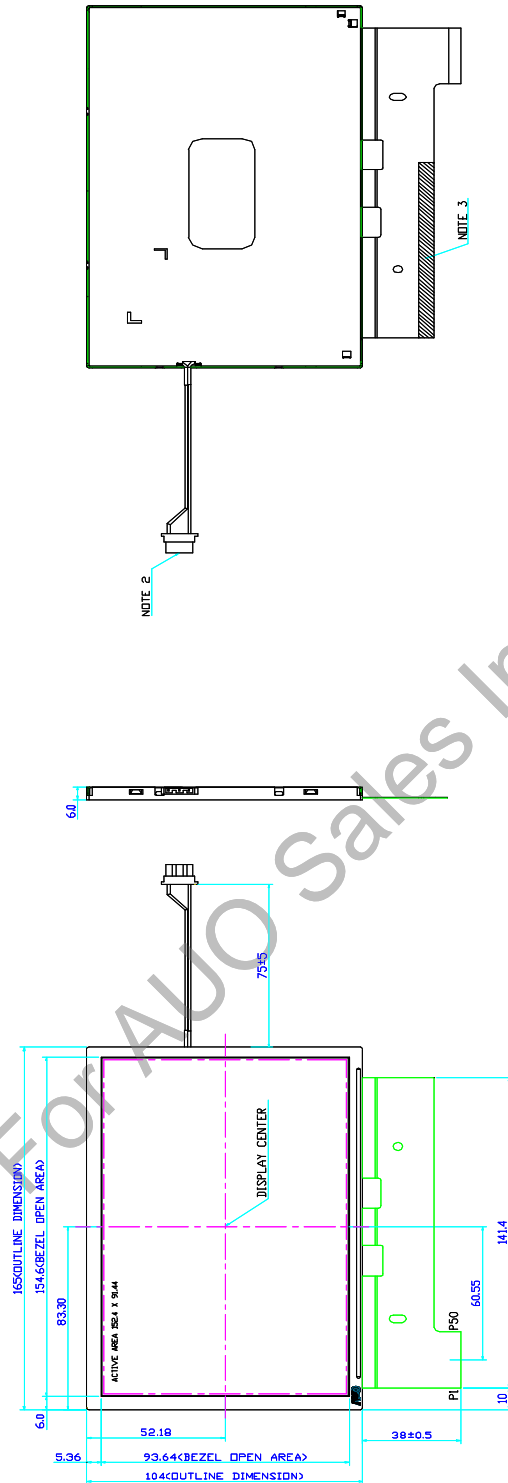

- NOTES:
1. General Tolerance : ±0.3
  2. Lamp connector : JST/BHR-03VS-1
  3. TWO SIDE TAPE 80X6 mm

Fig.1 Outline dimension of TFT-LCD module

■ Timing Diagram 1 (CHNSL="1", Default)

<< EDGSL="0", Default >>

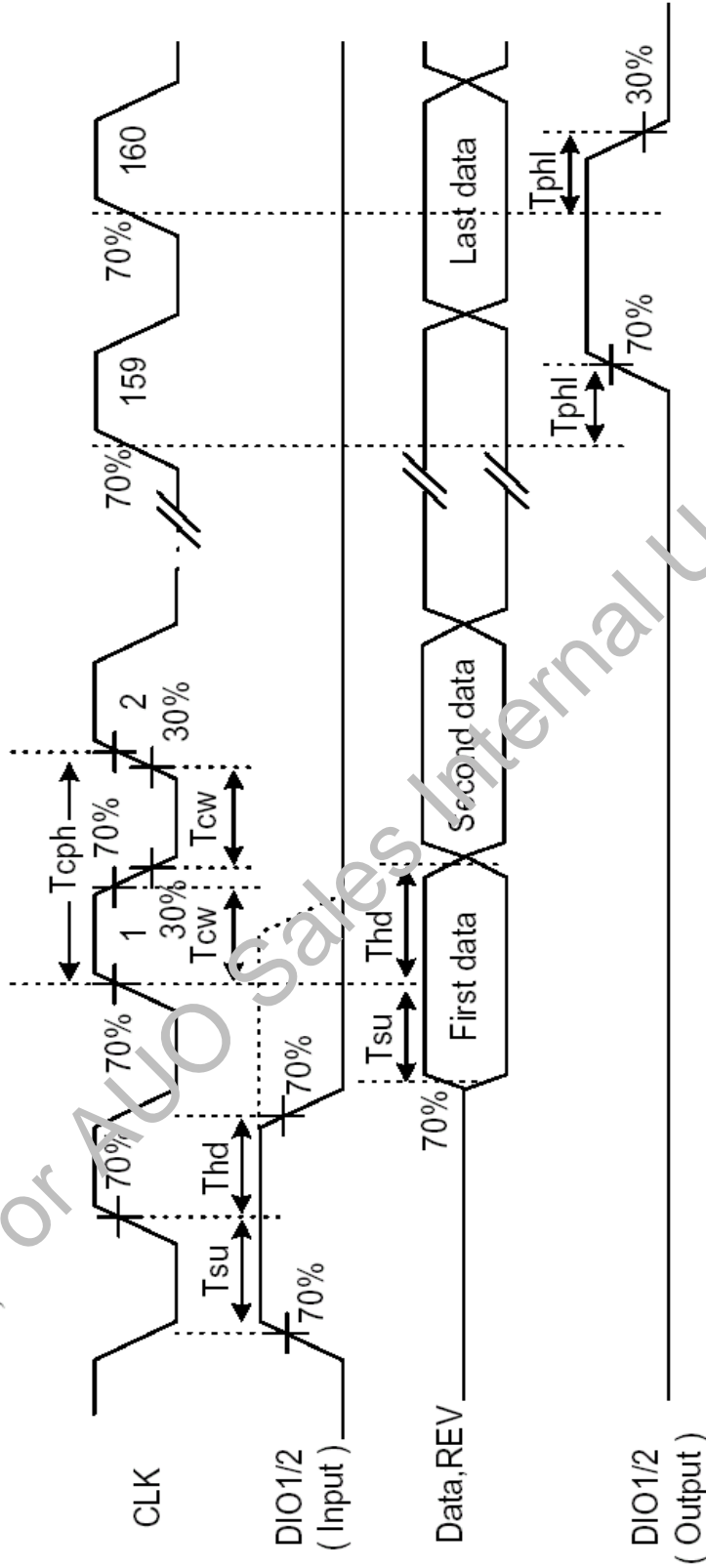

Fig.2 Operation Mode 1

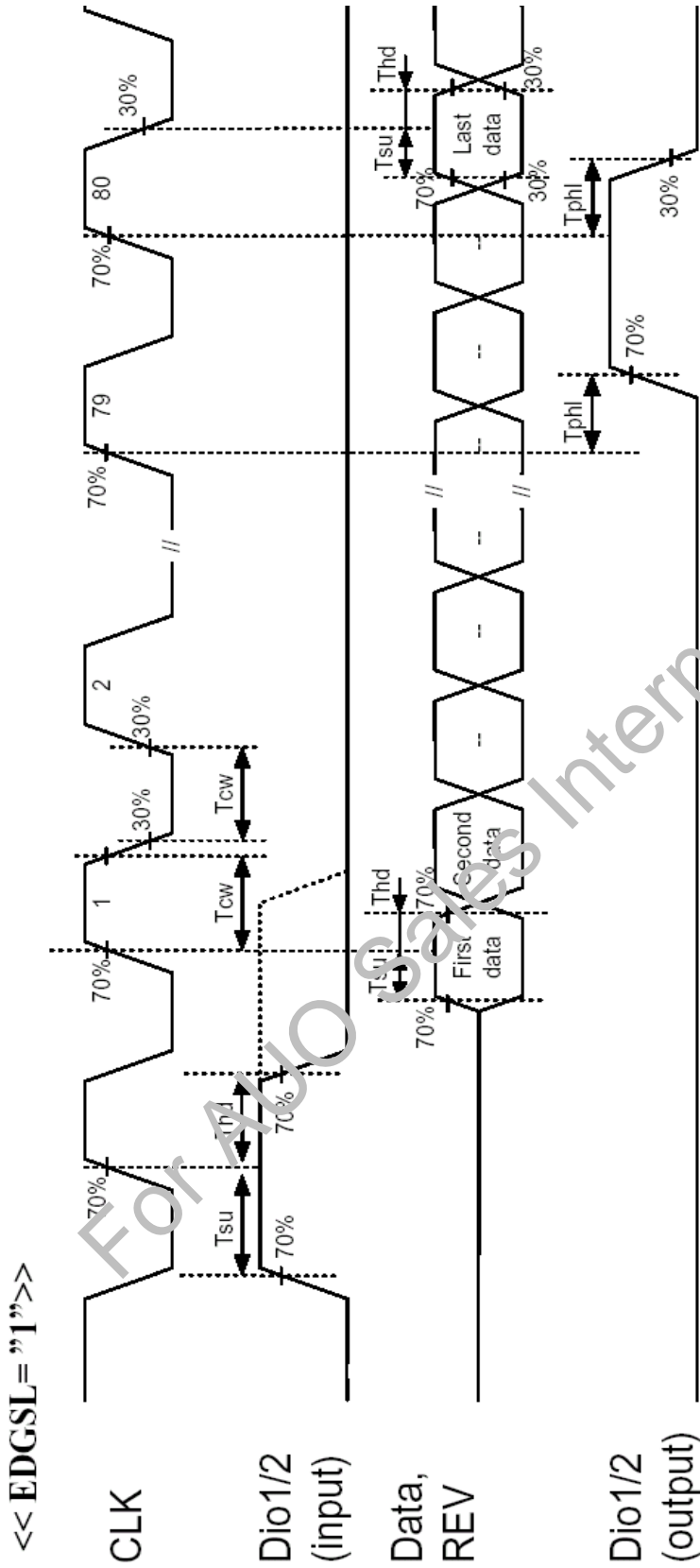
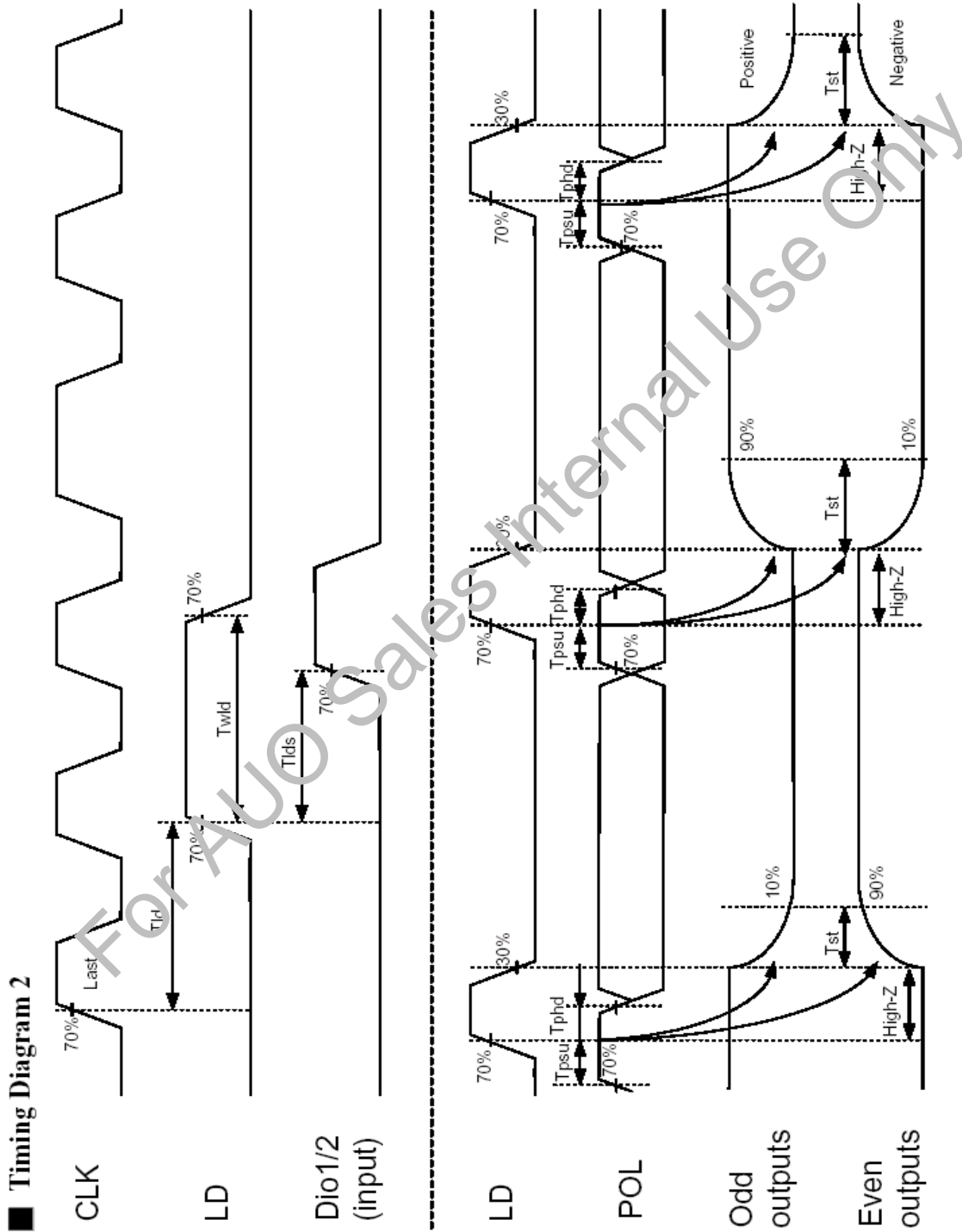
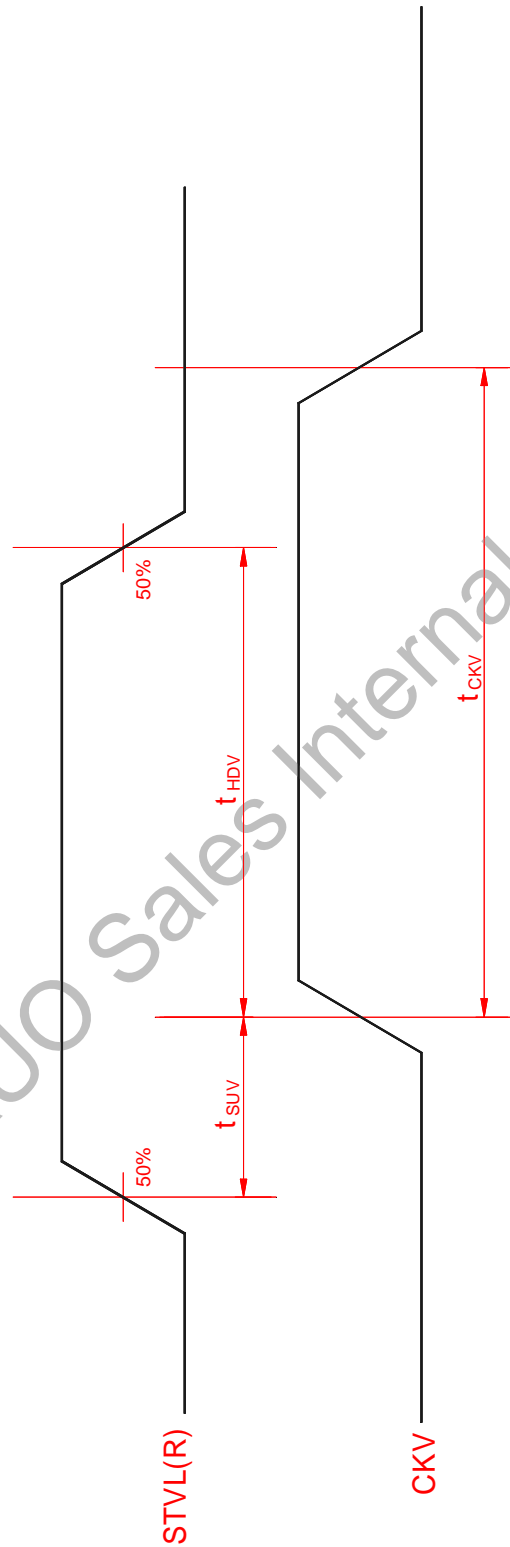

Fig.3 Operation Mode 2



**Fig.4 Horizontal timing**



For AUO Sales Internal Use Only

Fig.5 Vertical shift clock timing

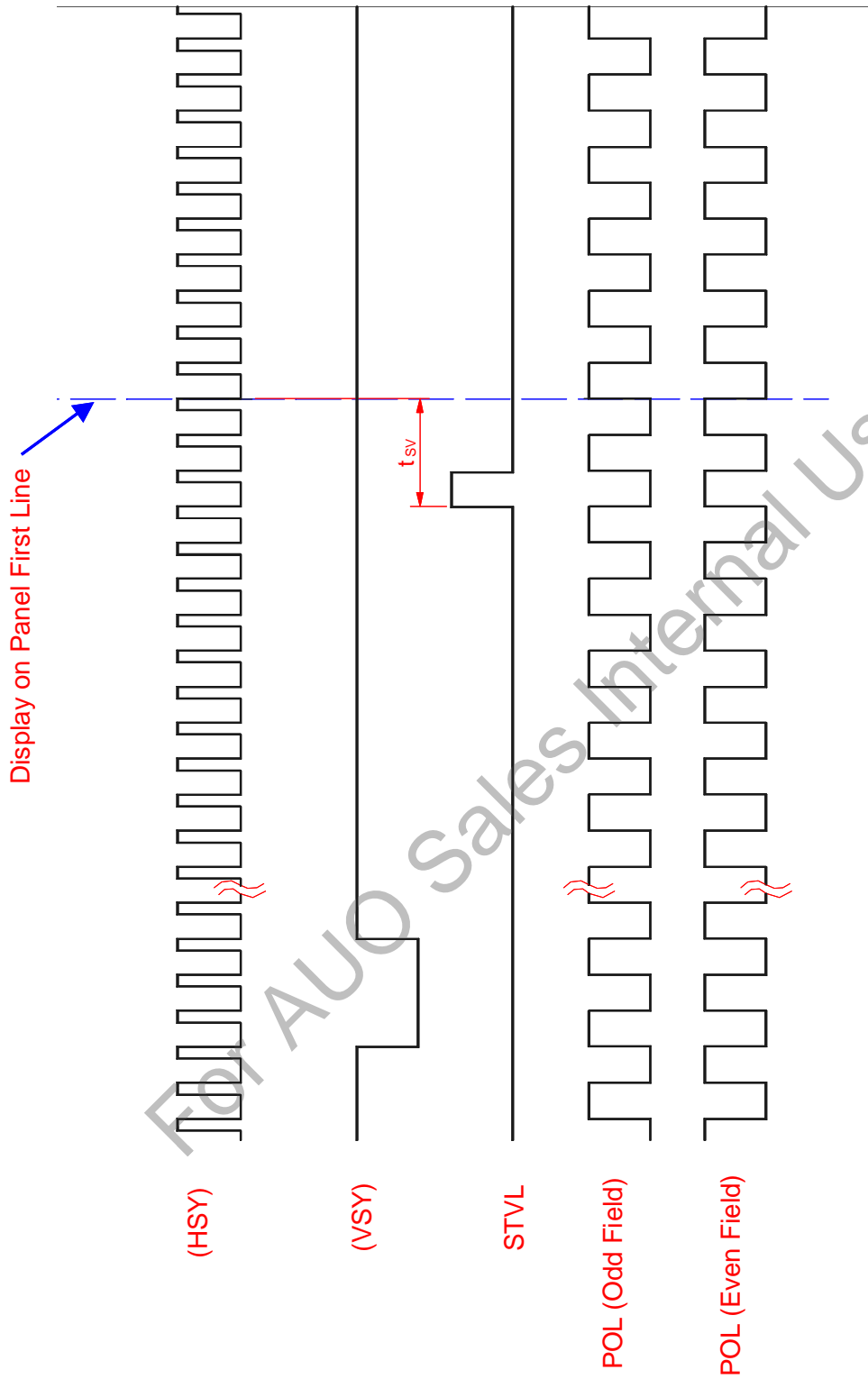

Fig.6 Vertical timing (from up to down)